

PERSONAL MONITORING OF BENZENE IN PERTH, WESTERN AUSTRALIA: RESULTS OF A PILOT TRIAL

A Horton* and F Murray

Environmental Science, Murdoch University, Perth, Western Australia

ABSTRACT

As part of a larger study co-ordinated in four cities by the Western Australian Department of Environmental Protection to characterise non- industrial personal exposure to Benzene, Toluene, Ethylbenzene and Xylene (BTEX), a pilot trial was conducted in Perth, Western Australia. The objectives of the pilot trial were to assess the use of passive samplers in the measurement of BTEX at a range of concentrations over 24 hours, evaluate the ease of use of a self administered questionnaire and a time/ activity diary, and to trial the logistics of conducting a personal exposure study. The results of the pilot trial indicated the questionnaire and diary effectively revealed potential lifestyle and behavioural factors that influence personal exposure to benzene. The BTEX samplers also proved effective in measuring a range of benzene concentrations, and did not limit the behaviours or activities of the participants whilst being worn.

INDEX TERMS

Benzene, Pilot trial, Personal exposure monitoring

INTRODUCTION

Benzene is an organic compound that is widespread in the environment. Due to the number of sources and uses of benzene, there is significant potential for exposure in the community (IPCS, 1993; Thomas *et al.*, 1993; Heavner *et al.*, 1995). Exposure to high concentrations of benzene in industrial settings has been shown to cause serious health effects including leukaemia (Rinsky *et al.*, 1987; Paustenbach *et al.*, 1992), however, the health effects of long term exposure to the low concentrations of benzene that have been measured in Australian cities are not fully understood.

Many studies of non- industrial exposure to benzene in community settings worldwide have shown that exposure is significantly influenced by personal activities rather than emissions from point sources (Wallace, 1989), as was previously understood (Pellizzari *et al.*, 1987a; Pellizzari *et al.*, 1987 b). In addition, a number of other factors including behaviour and lifestyle have also been shown to influence personal exposure to benzene (Chan *et al.*, 1990; Leung and Harrison, 1998).

* Contact author email: ahorton@essun1.murdoch.edu.au

METHODS

Participant recruitment

Targetted recruitment was used to select 10 suitable individuals (an equal number of both genders) likely to be exposed to a wide range of BTEX concentrations. The inclusion criteria used were that the participants:

- must be non smokers, however they may reside in a household where one or more members of the family is a smoker
- are employed in an occupation which may result in increased personal exposure such as petrol station employees, couriers and bus/ taxi drivers
- drive automobiles, catch trains/ buses or cycle to and from work every day
- spend significant amounts of time in and around the home (child minding or retired)
- be at least 18 years of age.

Participants were recruited from Murdoch University via an email mailing list within the School of Environmental Science, from the Department of Environmental Protection and other associates and friends. In order to ensure anonymity, a Personal Identification number (PIN) was allocated to all participants in the pilot trial, and was recorded on the consent form, questionnaire, time/activity diary and record sheet prior to the provision of these materials to each participant.

An initial appointment was made with each recruit, during which some background information about the study was given, in addition to instructions concerning the use, handling and storage of the BTEX samplers, time/ activity diary and record sheet. Participants were then asked to sign the written consent form and spend approximately 5 minutes completing the questionnaire. Throughout the trial, regular contact was maintained with the participants to ensure that the BTEX samplers were worn, the diaries completed and any problems encountered could be resolved. Upon completion of the personal exposure monitoring, an additional appointment was made with the participant during which the BTEX samplers, questionnaire, time/ activity diary and record sheet were collected.

Sampling methodology

Each participant was provided with 9 BTEX samplers. Each participant was asked to wear a BTEX sampler for 24 hours on seven consecutive days, and to complete a record sheet by noting the date and time the BTEX sampler was opened, the date and time the BTEX sampler was closed, and any comments which could influence analysis on the record sheet. For ease of use of the record sheet, the BTEX sampler serial numbers were recorded for each participant prior to the provision of the record sheet to each participant. The average daily Perth temperature during the exposure period (required for analysis of the BTEX samplers) was obtained from the Bureau of Meteorology.

On one day, each participant was asked to wear a replicate sampler, and the remaining BTEX sampler was kept by the participant as a blank. Whilst wearing the BTEX sampler, a time/ activity diary was completed by each participant by outlining locations visited and activities performed. The time/ activity diary was based on a review of similar diaries used in other studies of personal exposure that focussed on typical microenvironments such as indoors and outdoors, and activities performed in these microenvironments (Schwab *et al.*, 1990; Freeman *et al.*, 1999). The diary was structured to account for the presence of a smoker, as previous studies indicated that this influenced the degree of personal exposure (Freeman *et al.*, 1991;

Klepeis *et al.*, 1995; Freeman *et al.*, 1999). Prior to the commencement of the personal monitoring, each participant was asked to complete a questionnaire requesting information concerning their age, gender, lifestyle and potential sources of BTEX around their home, as evidence from questionnaires used in previous studies indicated that these factors, amongst others, influenced the degree of personal exposure (Thomas *et al.*, 1993; Jo and Moon, 1999; Hoffmann *et al.*, 2000).

BTEX sampler design

The BTEX samplers used in the pilot trial were passive stainless steel tubes (Perkin-Elmer™ ATD 400). Similar passive tubes have been used in a number of previous studies (Gilli *et al.*, 1994; Gonzalez- Flesca *et al.*, 1999, Hoffmann *et al.*, 2000). The diameter of each tube was 6.35 mm and the length was 90 mm (Figure 1). The adsorbent material used in the BTEX samplers was Chromosorb 106. The BTEX samplers were pre-cleaned before each sampling period by heating under a stream of ultra high purity helium and then sealed to 3 psi with Swagelok caps containing PTFE ferrules (this was sufficient to allow for the lower pressure the BTEX samplers experienced during transportation by air to CSIRO Division of Atmospheric Research for analysis).

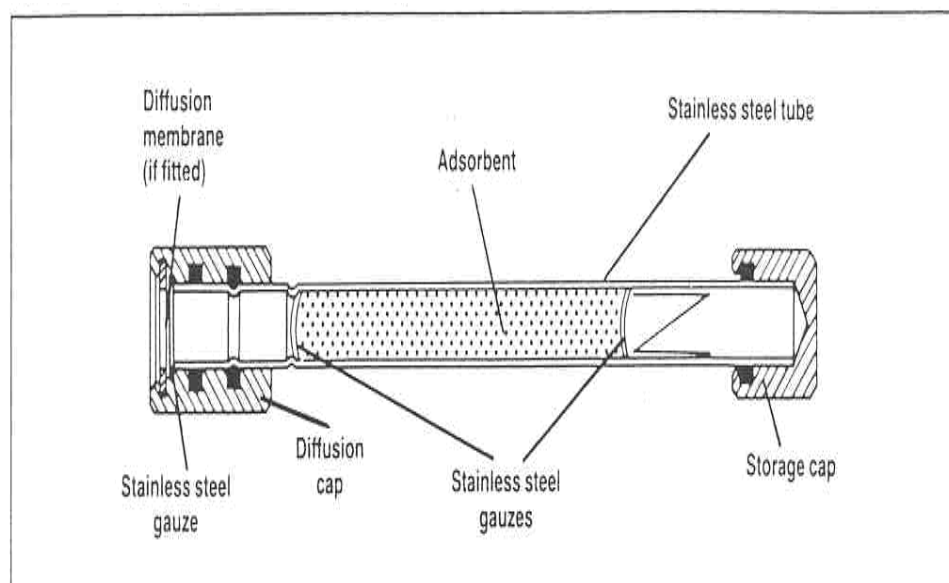

Figure 1. Diagram of a BTEX sampler fitted with a diffusion cap as worn by each participant in the pilot trial.

Preparation and Analysis of BTEX samplers

The BTEX samplers were prepared and analysed by CSIRO Division of Atmospheric Research. The samplers were loaded into a Perkin-Elmer Automated Thermal Desorption (ATD) 400™ System and sealed in a stream of ultra high purity helium and heated at 220 °C for 15 minutes to remove the benzene trapped on the adsorbent. PTFE storage caps used to seal the BTEX samplers during cleaning were replaced with Swagelok caps. Swagelok caps were used to seal the tube during transport and long-term storage and were tightened one 90° turn from finger tight using two spanners. The BTEX samplers were individually wrapped in aluminium foil baked at 400 °C for 5 hours, which provided a layer of protection against diffusion of benzene onto the tube if a cap did not seal correctly.

Each analytical run consisted of flushing the system with at least two injections prior to performing two standard injections. BTEX samplers were unpacked from the tin and foil and the Swagelok caps were replaced with PTFE storage caps. The BTEX samplers were loaded into the Perkin-Elmer Automated Thermal Desorption (ATD) 400™ System for analysis and upon completion of the run, two more flushes of the standard lines and two standard injections were performed. Desorbed benzene was transferred via a heater line to a gas chromatograph where it was detected with a flame ionisation detector.

The mean response of the four standard injections was used to calculate the concentration/area response for that run. The standard gases used were a mixture of benzene, toluene, ethylbenzene, *m*-xylene and *o*-xylene purchased from Scott Specialty Gases, San Bernadino, CA, USA. These were transferred onto the GC column via the ATD 400. A loop with a volume of 0.812 ml was heated to 80°C and filled at a flow rate of 50-60 ml/minute with the standard gas, which was injected into the helium carrier gas stream in the ATD 400.

RESULTS

Questionnaire

The questionnaire used in the pilot trial proved to be an effective, simple to use tool to gain an insight into the behavioural and lifestyle factors that potentially influence the participants' personal exposure to BTEX, and the sources of BTEX around their homes. In terms of lifestyle factors, there was a range of responses in the questionnaire concerning the frequency of purchase of food and beverages from drive through outlets by the participants, the frequency of participants refuelling their automobiles, and the use of various consumer products in and around their homes. A range of responses to these factors in the questionnaire is important given that individuals who were likely to be exposed to a wide range of BTEX concentrations were chosen to participate, and if each participant's responses were similar, the wide range of BTEX concentrations to which they were exposed may not be revealed.

Time/ Activity Diary

The time/ activity diary used in the pilot trial also proved effective in defining the environments the participants visited over a 24-hour period and the activities performed while in these microenvironments. Each participant completed the time/ activity diary with little difficulty, and a large number of indoor and outdoor environments were visited over each 24-hour period for the duration of the pilot trial, and a variety of activities were performed while the participants were in those microenvironments. Similar to the questionnaire, the number of environments visited and activities performed over each 24-hour period may have reflected the wide range of BTEX concentrations to which the participants were exposed during the pilot trial. Importantly, the majority of participants completed each day of the diary to within one hour of the 24 hours for which it was to be completed. This provided an accurate picture of the number of environments visited and activities performed by each participant over each 24-hour period for which the time/ activity diary was completed.

BTEX samplers

Participant feedback indicated that the BTEX samplers used in the pilot trial were relatively easy to operate and did not limit the extent of environments visited and activities performed whilst the BTEX samplers were worn. There was little variation in the benzene concentrations obtained from the BTEX samplers worn for 7 consecutive 24-hour periods by participants, however the benzene concentrations obtained from the BTEX samplers worn by one participant who was occupationally exposed were on average one order of magnitude higher than that of the other participants.

DISCUSSION

The questionnaire and time/ activity diary were both adequately completed by all participants, and the BTEX samplers were easily operated by all of the participants during the pilot trial. Therefore, all materials used in the pilot trial were considered appropriate for use in a larger study involving 200 participants conducted in Perth, Adelaide, Melbourne and Sydney.

ACKNOWLEDGMENTS

The authors would like to thank CSIRO Division of Atmospheric Research for preparing and analysing the BTEX samplers. We would also like to acknowledge the assistance of the Department of Environmental Protection in Western Australia, the Victorian, South Australian and New South Wales Environmental Protection Authorities, the New South Wales Department of Health, Monash University, Flinders University, the University of Western Australia Department of Public Health and funding provided by Environment Australia (Air Toxics- Living Cities Program).

REFERENCES

- Chan, C-C., Spengler, JD., Ozkaynak, H., Lefkopoulou, M., (1990) Commuter Exposures to Volatile Organic Compounds. *Indoor Air '90: Proceedings of the 5th International Conference on Indoor Air Quality and Climate* vol. 2, 627- 632 Toronto, Canada, the conference.
- Freeman, NCG., Waldman, JM., Lioy, PJ., (1991) Design and Evaluation of a Location and Activity Log Used For Assessing Personal Exposure to Air Pollutants *Journal of Exposure Analysis and Environmental Epidemiology* **1** (3), 327- 338.
- Freeman, NCG., Lioy, PJ., Pellizzari, E., Zelon, H., Thomas, H., Clayton, A., Quackenboss, J., (1999) Responses to the Region 5 NHEXAS time/ activity diary *Journal of Exposure Analysis and Environmental Epidemiology* **9** (5), 414- 426.
- Gilli, G., Scursatone, E. and Bono, R. (1994) Benzene, toluene and xylenes in air, geographical distribution in the Piedmont region (Italy) and personal exposure *The Science of the Total Environment*, **148**, 49-56.
- Gonzalez-Flesca, N., Cicolella, A., Bates, M. and Bastin, E. (1999) Pilot Study of Personal, Indoor and Outdoor Exposure to Benzene, Formaldehyde and Acetaldehyde *Environmental Science and Pollution Research*, **6**, 95-102.
- Heavner, D., Morgan, WT., Ogden MW., (1995). "Determination of Volatile Organic Compounds and ETS Apportionment in 49 homes." *Environment International* **21** (1), 3-21.
- Hoffmann, K., Krause, C., Seifert, B., Ullrich, D., (2000) The German Environmental Survey 1990/92 (GerES 2): Sources of personal exposure to volatile organic compounds *Journal of Exposure Analysis and Environmental Epidemiology* **10** (2), 115- 125.
- International Programme on Chemical Safety (IPCS) (1993). Environmental Health Criteria 150: Benzene. World Health Organisation, Geneva.
- Jo, W-K., Moon, K-C., (1999) Housewives' exposure to volatile organic compounds relative to proximity to roadside service stations *Atmospheric Environment* **33** (18), 2921- 2928.
- Klepeis, NE., Tsang, AM., Behar, JV., (1995) Analysis of the National Human Activity Pattern Survey (NHAPS) Respondents From A Standpoint of Exposure Assessment, Report no. 68-01-7325 National Exposure Research Laboratory, Office of Research and Development, Las Vegas, NV (USA) United States Environmental Protection Agency, September 1995.
- Leung, P-L., and Harrison R., (1998). "Roadside and in- vehicle concentrations of monoaromatic hydrocarbons." *Atmospheric Environment* **33** (2), 191-204.
- Paustenbach, DJ., Price, PS., Ollison, W., Blank, C., Jernigan, JD., Bass, RD., Peterson, HD.,

- (1992) Reevaluation of Benzene Exposure for the Pliofilm (Rubberworker) Cohort (1936-1976) *Journal of Toxicology and Environmental Health* **36** (3), 117- 231.
- Pellizzari, E., Perritt, R., Hartwell, TD., Micheal, LC., Sheldon, LS., Sparacino, CM., Whitmore, R., Leninger, C., Zelon, H., Handy, RW., Smith, D., Wallace, LA., (1987a). Total Exposure Assessment Methodology (TEAM) Study: Elizabeth and Bayonne, New Jersey; Devil's Lake, North Dakota, and Greensboro, North Carolina, Vol. 2. Washington DC, United States Environmental Protection Agency.
- Pellizzari, E., Perritt, R., Hartwell, TD., Michael, LC., Sheldon, LS., Whitmore, R., Leninger, C., Handy, RW., Smith, D., Zelon, H., Wallace, LA., (1987b). Total Exposure Methodology (TEAM) Study: Selected Communities in Northern and Southern California, Vol. 3. Washington DC, United States Environmental Protection Agency.
- Rinsky, RA., Smith, AB., Hornung, R., Filloon, TG., Young, RJ., Okun, AH., Landrigan, PJ., (1987) Benzene and Leukemia *The New England Journal of Medicine* **316** (17), 1044-1050.
- Schwab, M., Colome, SD., Spengler, JD., Ryan, PB., Billick, IH., (1990) Activity Patterns Applied to Pollutant Exposure Assessment: Data from a Personal Monitoring Study in Los Angeles *Toxicology and Industrial Health* **6** (6), 517- 532.
- Thomas, K., Pellizzari, ED., Clayton, CA., Perritt, RL., Dietz, RN., Goodrich, RW., Nelson, WC., Wallace, LA (1993). "Temporal Variability of Benzene Exposures for Residents in Several New Jersey homes with attached garages or tobacco smoke." *Journal of Exposure Analysis and Environmental Epidemiology* **3**, 49-73.
- Wallace, LA., Pellizzari, ED., Hartwell, TD., Davis, V., Michael, LC., Whitmore, RW.,(1989) The Influence of Personal Activities on Exposure to Volatile Organic Compounds *Environmental Research* **50**, 37- 55.