

Assembled anchor:

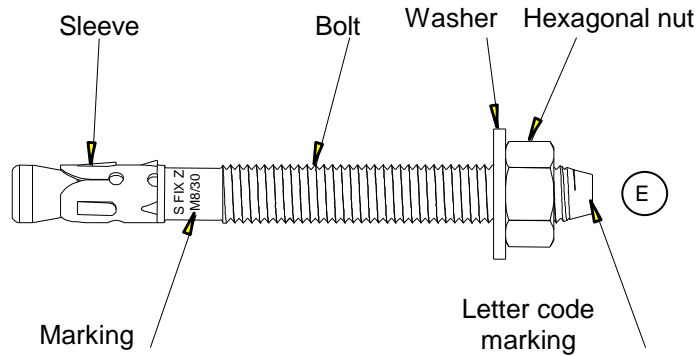

Marking: on the bolt, S FIX Z identifying mark of the producer and commercial name.
 on the head, M8/30 nominal diameter and maximum fixture thickness $t_{fix,max}$.
 E letter code that is function of the total length of the bolt
 (based on the International Conference of Building Officials system).

Letter code	A	B	C	D	E	F	G	H	I	J	K	L	M
Total length of the bolt (mm)	38 < < 51	51 < < 63	63 < < 76	76 < < 89	89 < < 102	102 < < 114	114 < < 127	127 < < 140	140 < < 152	152 < < 165	165 < < 178	178 < < 191	191 < < 203
Letter code	N	O	P	Q	R	S	T	U	V	W	X	Y	Z
Total length of the bolt (mm)	203 < < 216	216 < < 229	229 < < 241	241 < < 254	254 < < 279	279 < < 305	305 < < 330	330 < < 356	356 < < 381	381 < < 406	406 < < 432	432 < < 457	457 < < 483

Schema of the anchor in use:

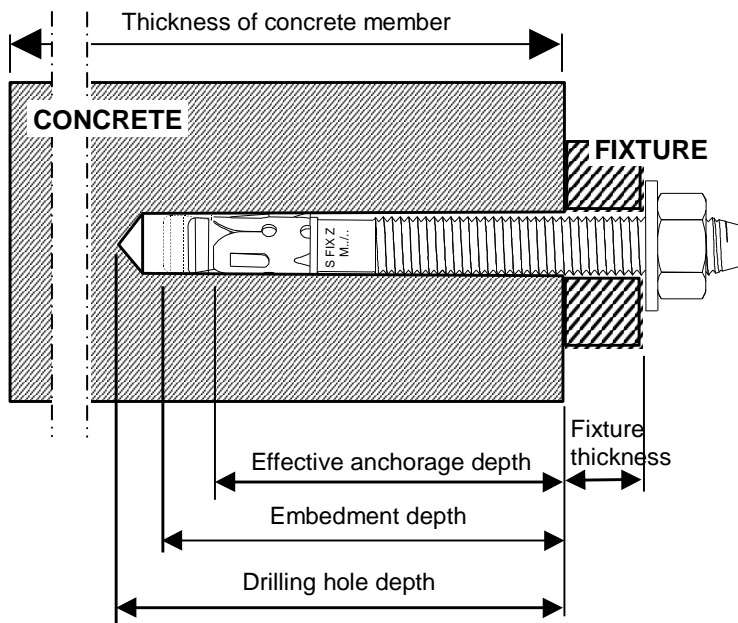

ELEMATIC ETD Z torque-controlled expansion anchor	Annex 1 of European Technical Approval ETA-02/0045
Product and intended use	