

### Installed condition

**Figure A1:**  
Threaded rod, HIT-V...

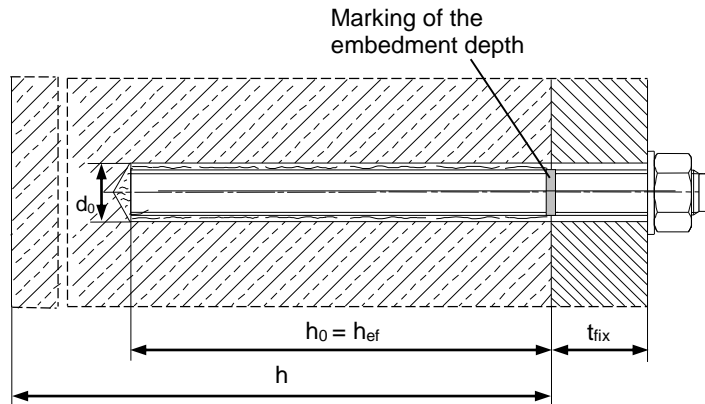

**Figure A2:**  
Internally threaded sleeve HIS-(R)N

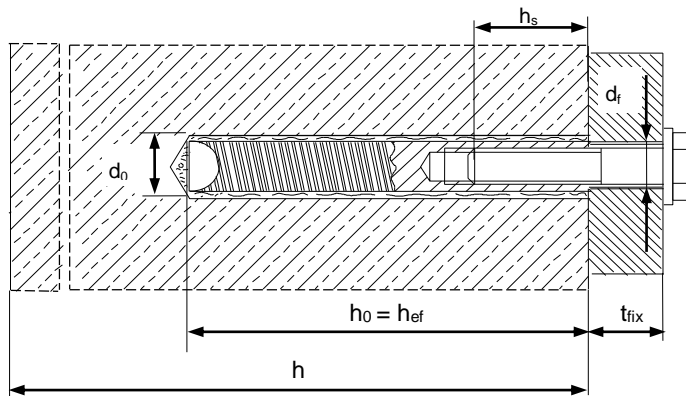

**Figure A3:**  
Reinforcing bar (rebar)

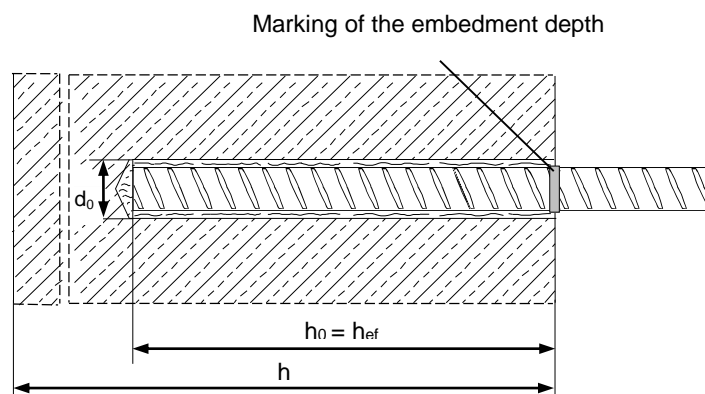

Injection system Hilti HIT-RE 500 V3

Product  
Installed condition

Annex A1