

Threaded anchor rods

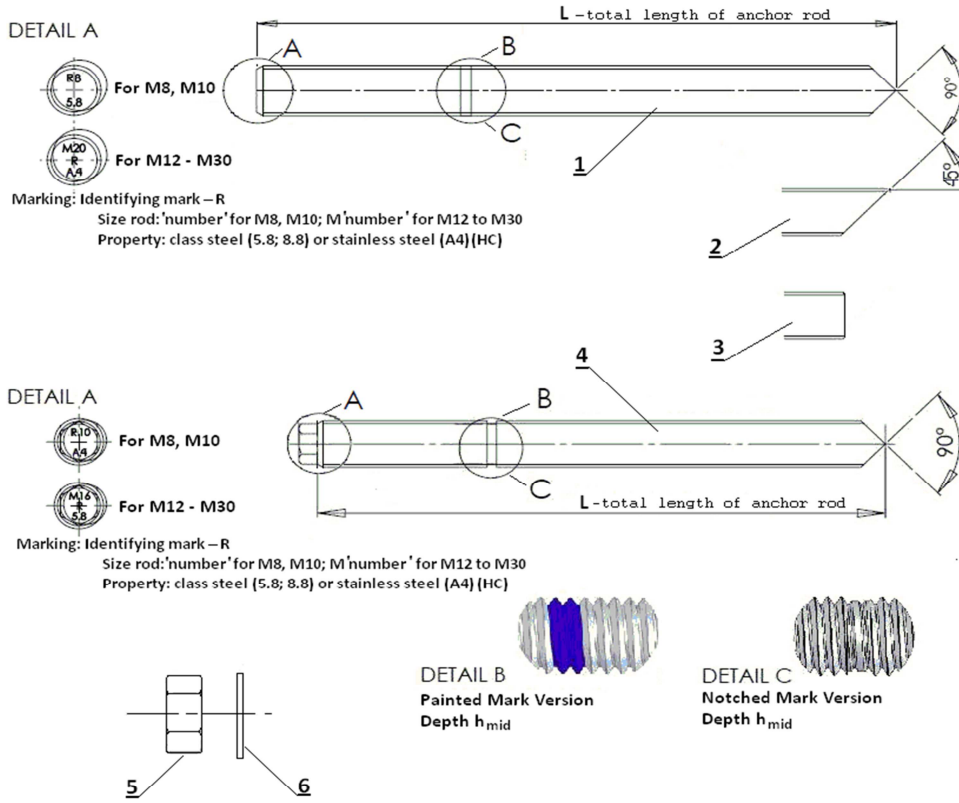

R-KER-II, R-KER-II-S and R-KER-II-W

Threaded anchor rods

Annex A1
of European
Technical Assessment
ETA-17/0594