

Types of plan

Type 16G

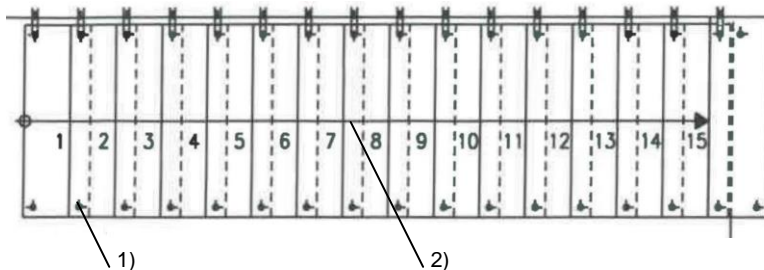

In the area of openings
wall-replacement-beams are
possible (see Annex A3).

- 1) additional support
(according to Annex C2)
- 2) walking line is exemplified, position
may be chosen freely within the
walking zone, walking zone is 20 % of
the clear width of the stair in the
middle of the stair

Type 16V

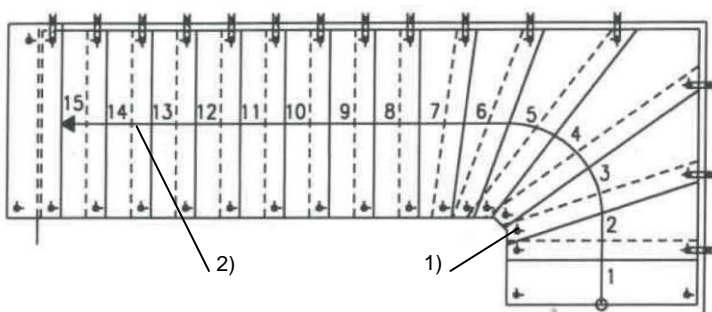

Type 16VV

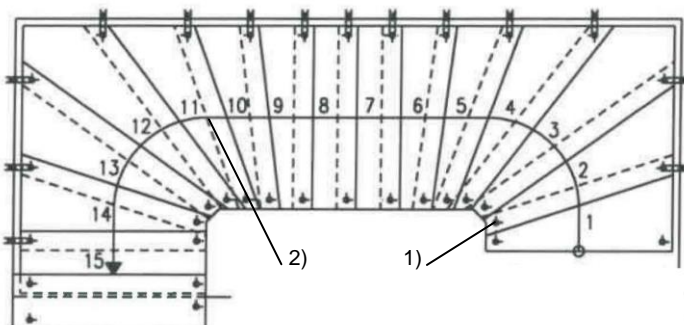

Type 16H

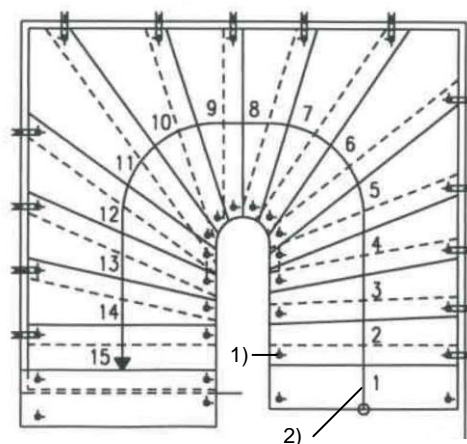

Types of construction

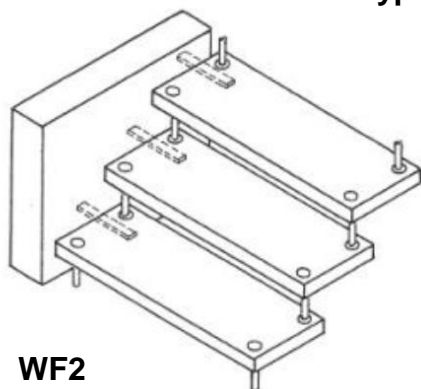

WF2

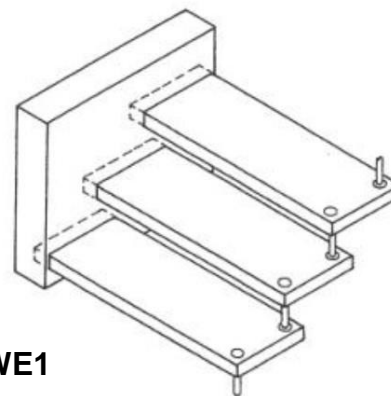

WE1

Meckel & Weyel GF – stone stair

Product

Annex A1