

ERGONOMICS METHODS APPLIED TO HEALTHCARE ARCHITECTURE

J. Lu, S. Hignett

Department of Human Sciences, Loughborough University,
Loughborough, LEICS, LE11 3TU, UK

E-mail: j.lu@lboro.ac.uk

ABSTRACT: Designing a healthcare facility without giving sufficient consideration to the users who will perform their activities in it may lead to dysfunctional workplaces. Some ergonomic methods can be used to provide key information to designers so that better decisions can be made to achieve a safe and efficient healthcare environment. The project uses ergonomic methods to review hospital drawings produced over 20 years ago. This paper describes two ergonomic methods used to look at the single bed space in hospital design. Data were collected from: 1.) Observations of clinical activities in local hospitals using Hierarchical Task Analysis, which helped the researcher understand clinical activities in detail; 2.) Simulation of clinical activities in the bed space mockup using Link Analysis to look at spatial relationships within a defined area, and then determine the optimal dimension. The final outcomes will include recommendations to be used for the efficient design of hospitals.

Keywords – Ergonomic methods, hierarchical task analysis, hospital design, link analysis.

1. INTRODUCTION

Although it has been known for some time that architectural design could benefit from ergonomics / human factors, hospitals, as a complex system where there are various users of equipment, products and treatment / care environment, are still often designed without giving sufficient consideration to the users who will perform their activities in it, leading to dysfunctional workplaces (Villeneuve, 2004). Some ergonomics methods can be used to provide key information (for example, user-needs analysis and task analysis) to designers of hospitals so that better decisions can be made in design and planning to achieve a safe and efficient healthcare environment.

1.1 Background

In the early 1980s the Department of Health and Social Security (DHSS) developed an ergonomic database made up of data sheets, which contained a large number of drawings that “give the space requirements for activities and other ergonomics information relating to the use of spaces within hospital and health buildings” (Hilliari, 1981). The relevant data sheets were then attached to the DHSS’s published Health Building Notes (HBN) series to act as guidance for the design of new hospitals and the adaptation of old buildings, and encouraged those involved in hospital design to think in terms of the relationship between a user and a particular component and other components located within a room to produce a more efficient planning of space.

Since the majority of those ergonomic drawings were initially developed over 20 years ago, questions have been raised about whether they are capable of reflecting changes in clinical practice and medical technology; whether the people involved in

hospital development, e.g. architects, use the drawings while developing designs and whether the drawings work with respect to the functionality and usability of care and treatment environments.

1.2 Research aim

The project funded by NHS Estates is reviewing the drawings by looking at the highest repeating unit in hospital design i.e. the single bed space in single rooms and multi-bed bays based on acute adult wards and intensive care units (ICU) in terms of four key clinical activities: manual handling, resuscitation, disability access, and infection control.

2. METHODOLOGY

The project has passed through the following phases:

1. Literature review of studies concerned with the development and use of ergonomic drawings in healthcare in the context of changes in clinical practice over the last 20 years.
2. Expert interviews to elicit the views of architects, healthcare planners, and facilities managers, etc about the use of ergonomic drawings and patient rooms.
3. Anthropometric benchmarking to collect data on the dimensions and layouts of single bed rooms, multi-bed bays from 5 sites built within the last 10 years. The data were then used to set up the full-size mockups for laboratory based simulations.
4. Observations in single patient room and multi-bed bay at hospitals; and then simulations of nursing tasks for different layouts to collect and analyse data using hierarchical task analysis (HTA) and link analysis (LA).
5. The final data analysis will bring together the anthropometric and task analysis data in a comparative review and produce recommendations for revised and new ergonomic drawings.

From the literature review, we found that although NHS Estates regularly update the HBNs, very little research-based evidence is available to provide a rationale for the changes in the recommended dimensions. From the literature it is difficult to find out whether the ergonomic drawings work and whether architects use ergonomic information extensively while designing (Lu and Hignett, 2005). From the expert interviews preliminary findings suggest that architects have not used the drawings as guidance consistently or historically, and that most would prefer a simpler form of design guidance.

The researchers visited 5 sites (recruited from 25 hospitals) built or refurbished in the last 10 years and measured bed spaces in both adult acute wards and intensive care units. We have found many of these dimensions are less than the HBN recommendations (Lu and Hignett, 2005).

We observed nursing tasks on the ICU at a local hospital for one week and on acute adult wards at second local hospital for 4 weeks to understand the tasks in more detail. These data were used to design the task scenarios to be “enacted” in the mockups to test the different bed spaces during simulation phase.

At present the simulation work is nearing complete, and the following data

analyses are on-going.

2.1 Task analysis methodologies

Since healthcare is a relatively new area of practice for ergonomics, we propose there are methodologies from other safety critical environments which have been developed in the last 20 years that could be used for the review of existing ergonomic drawings as well as the development of new ergonomic envelopes.

In this paper, we describe task analysis methodologies applied to collect and analyse data during field observations on an ICU and simulations of the ICU bed spaces in an experiment laboratory at the university.

2.2 Ethical issues and paperwork preparations

As all research in the NHS should be reviewed and approved by the ethics and research governance committees. We submitted the documents before the observations and simulations. The documents included the completed application forms, the research protocol, different participant information sheets and consent forms (for nurses in observations and simulations respectively and patients in observations), we were granted approval after 5 months. The researchers have also had honorary contracts for working at both hospitals.

2.3 Observations

As aforementioned, in order to investigate how the tasks of manual handling, resuscitation, infection control and disability access were carried out and what was really going on in the bed space during such a task, 1 week of observations were undertaken.

2.3.1 Study setting and subjects

The observation areas were sited in the cardiac intensive care unit (CICU) at an acute hospital of around 520 beds from University Hospitals of Leicester NHS Trust which provided a range of in-patient, day case and outpatient services. The subjects were nursing staff and post-op patients on the CICU.

As patients on the unit were very vulnerable and most of them were unconscious in the first 2 –3 hours after they were brought from the operating theater, they were approached (under the guidance of nursing staff) on the day before their operation and provided with an information sheet to explain the project, what they would be invited to do, and what their own rights were, etc. If they agreed to permit the observation of nursing tasks, they were asked to sign a consent form.

The nurses were approached, given a different information sheet and asked to sign the consent form on the observation day.

2.3.2 Data collection

As the researcher/observer (JL) had little experience of conducting observations in a clinical environment, a pre-pilot and a pilot were undertaken on the CICU on two days respectively:

- to test and develop the initial observation protocol and data collection sheets;
- to practise observations of nursing tasks;
- to become familiar with the unit and nurses;
- to get a general perspective of nursing tasks and the equipment used.

A one-week observation was then carried out based on the revised protocol. Data collection on each day was undertaken during the morning shift from 0800am when the shift handover was normally complete till 1900pm when the next shift handover started. The researcher positioned herself at the end of the corridor of the unit where the bed spaces on both sides of the corridor were in sight so that the researcher could be aware of what tasks might occur in a certain bed space. Meanwhile, the nurses who allocated a participating patient were advised in advance on what kind of tasks the researcher would like to watch so that they could give notice before they started the relevant tasks in order to alert the researcher.

The observations were recorded by taking notes manually without any image recording due to the ethical requirements. As well as literal descriptions of the process of the task, the recorded data also included:

- the purpose of the task;
- the clinical area under observation;
- start and finish time of the task;
- where the observer was positioned while observing;
- all the participants;
- the sketch of the layout recording other details of observed area, such as the position of equipment, furniture, devices;
- lines drawn on the layout sketch briefly recording movements of components or elements of the observed area.

An observation diary was kept to record general information and additional data not recorded on the data sheets.

Although the researcher and nurses tried to ensure that the researcher recorded as many tasks as possible, some tasks were still missed, for example, concurrent tasks where the researcher had to choose one to observe and “abandon” another one. An order of priority was established for: new tasks, different nurse(s), and female patients (since fewer female patients were available). However some of the participating patients felt too uncomfortable (physically or psychologically) to let the researcher stay round the bed space to watch. In this situation the researcher stopped the observation when the shadowed nursing staff was attending to them and restarted the observations when the nurse indicated that it was appropriate to approach them or when the nurse went to another participating patient.

By the end of the observation period a total of 31 nursing tasks were recorded with 28 nurses providing care and treatment to 25 patients involved (Table 1).

Table 1. Overall data presentation of ICU observations

Tasks observed	Number of times tasks observed	Duration (mins)	No. of nurses involved	Patient's condition
• Washing, shaving a patient, changing bed sheets	1	40	2 – 3	Awake, dependent
• Washing a patient, changing bed sheets	14	30 – 40	2 – 3	Asleep/awake dependent
• Checking a patient's rectum / anus	1	5 – 10	1 – 2	Asleep
• Repositioning (moving / sliding) a patient on the bed	5	5	2 – 3	Asleep/awake dependent
• Washing, dressing, and moving a patient from bed to chair or wheelchair without a hoist	3	20 – 40	2 – 3	Awake, less dependent
• Dressing and moving a patient from bed to chair or wheelchair without a hoist	4	20 – 30	2 – 3	Awake, less dependent
• Moving a patient from chair to wheelchair	1	5	1 – 2	Awake, less dependent
• Transferring a patient from bed to bed	1	10	2 – 3	Awake, dependent
• Front chest X-ray with mobile X-ray machine	1	10 – 15	2 – 3	Asleep/awake dependent

2.3.3 Data analysis

The researcher used Hierarchical Task Analysis (HTA) for the data analysis. HTA is a technique to analyse data by breaking a task down into sub-tasks until a stopping point is reached when the task cannot be further broken/described (Shepherd, 2001). It was used to re-describe the recorded data to arrive at a detailed understanding of what nursing staff were required to do and how they accomplished their tasks (Figure 1). These data showed the individual variance in a specified task by different nursing staff and identified generic task components which were used to develop the simulation scenarios.

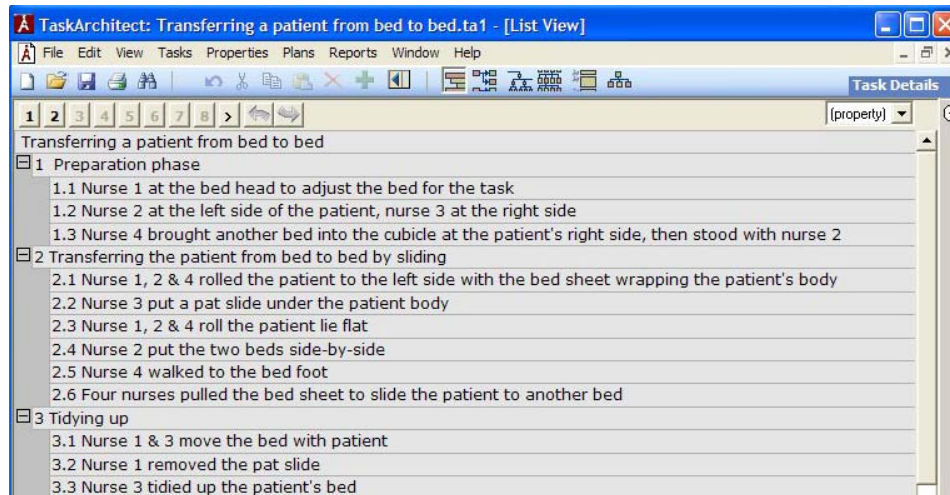

Fig.1. Example of HTA for transferring a patient from a bed to a 2nd bed

During the observational data analysis, the technique of link analysis was used to

- 1.) look at spatial relationships by recording and analysing movements between components, i.e. nursing staff, equipment/device and furniture within a bed space, and
- 2.) identify which task occupied more space, where the area with the higher density of activities were (Figure 2), to help the researchers decide which tasks to simulate.

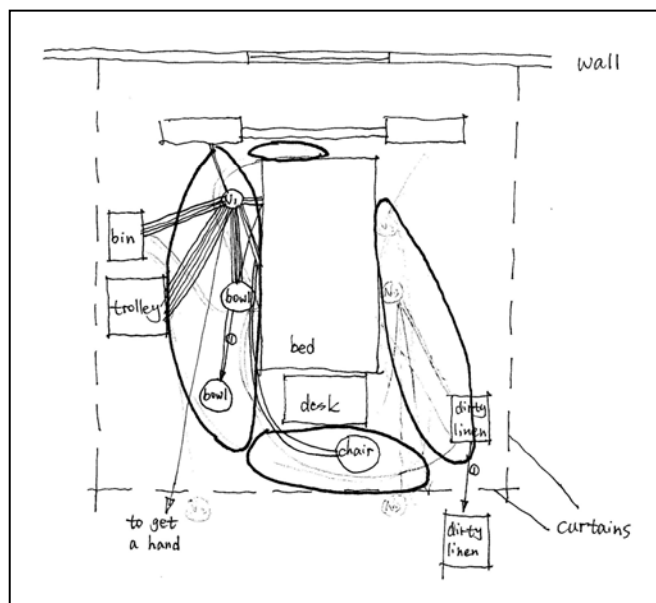

Fig.2. Link analysis of washing a patient and changing bed sheets

2.3.4 Summary of observational data

1. Items of equipment/furniture within a bed space on the observation site were found to be placed in similar positions to the sites visited during anthropometric benchmarking.
2. No tasks of resuscitation occurred during the observations. However, at the beginning of the project, the researcher attended training sessions for basic/advanced life support, and conducted pilots with experts in resuscitation and

manual handling to revise the research proposal. So these data were used to inform the simulation scenario.

3. The performances of infection control and disability access were analysed as sub-tasks, e.g. hand hygiene during clinical tasks.
4. The tasks of washing a patient and then change the bed sheets were the most frequently observed during the field data collection.
5. The bed head was the area occupied least during the tasks, while the side of the left hand shelf, i.e. the patient's right side, where the bin and the nurse trolley were located, was the area most occupied during the tasks.
6. Although no observations of nursing staff were made using a hoist, the researcher noted, and was advised, that the hoist was used quite frequently to move patients on the unit.

2.4 Simulations

2.4.1 Study setting and subjects

The simulations were designed to test the different bed space layouts and dimensions measured at hospitals during site visits. They were undertaken in full-scale mockups built at Healthcare Ergonomics and Patient Safety research Unit (HEPSU) laboratory of Loughborough University. The participants were the nursing staff from CICU at UHL.

A poster about nurse recruitment was displayed on the CICU notice board a few weeks before the start of the simulations. The researcher had informal conversations with nurses about the simulations during the observations and gave a verbal invitation to them to participate. The participating nurses were given the simulation information sheet and asked to sign the consent forms on the day of simulations.

2.4.2 Data collection

As with the observational phase, a pre-pilot and a pilot were undertaken at the lab on two days respectively with the help of nursing staff from the hospital:

- to review the observational data, and provide essential clinical information which the researcher wasn't able to access during the observations, e.g. the resuscitation task;
- to discuss and determine the tasks to be simulated;
- to review the simulation scenarios produced by researchers based on the observational data, especially to determine what and how the participants were going to perform, how many participants would be needed for a task, what equipment would be used, and the start and end points of the task, etc.;
- to improve the mockups;
- to test and improve the simulated equipment made out of cardboard;
- to set up and test the video cameras;
- to walk through the mockups with the tasks to be simulated to determine the number of sessions and nursing staff required for the simulations.

After the pilots, the following 3 tasks were chosen: 1.) washing and dressing a patient, and then moving them from bed-to-wheelchair by a hoist; 2.) resuscitating a patient, and 3.) transferring a patient from bed to another bed. Four ICU bed space

layouts were tested based on the data collected from site visit phase.

The researchers built the bed space mockups using the same layout and same size as those measured at the site visits. Different colour tapes were used to mark the floor to represent the boundaries of the different bed spaces. The researchers marked additional parallel lines at 20cm intervals on both sides of a boundary line to record and measure the exact space required for nursing tasks (Figure 3).



Three sessions were run in three days with 15 participating nurses. Each session had 2 groups of nurses, giving a total of 6 groups testing the layouts by repeatedly performing the above 3 tasks.

Data collection was undertaken by video recording for further analysis.

2.4.3 Data analysis

Link analysis was used to record the 1.) movements of components, i.e. nursing staff, equipment/device and furniture; and 2.) participants' (nursing staff's) movements among equipment/device, furniture and the simulation mannequin (patient) according to video footages. AutoCAD was used to draw the link diagrams as output to convey spatial information and the result of each layout tested.

Figure 4 shows the link analysis result of a bed space for the task of transferring a patient from a bed to another bed. Additional data analysis is being carried out and will be presented in future publications.

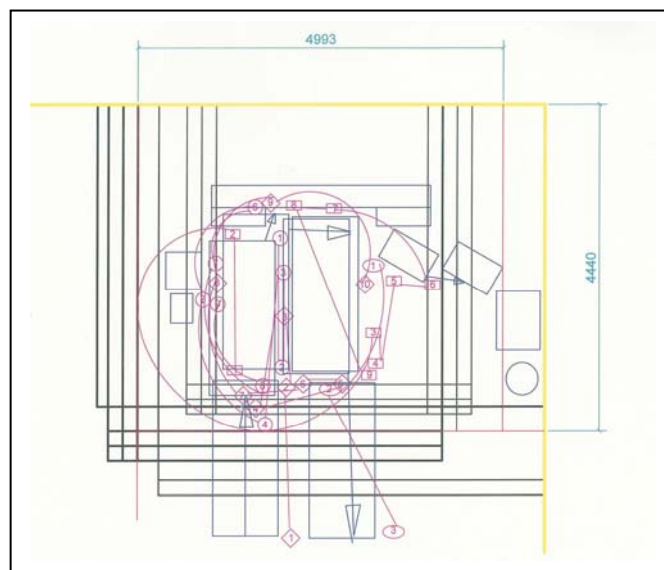

Fig.4. Link analysis of transferring a patient from bed to bed

3. DISCUSSION

Although the researchers built bed space mockups with the same layout and the same size as those measured during the site visits, mockups will never be equal to the real world. For example, cardboard equipment and a dummy patient were used to represent real medical equipment and a live patient. It was hard for the participating nurses to perform the tasks manipulating simulated elements/components with the same effort and posture as they did in their workplace. Next, participants might not have the same emotional response when performing a task in the mockup as in their workplace. For example, nurses may do a real resuscitation task with some emotional stress (Kozer et al, 2004), but as participants they may have performed the task without any pressure. This could lead to the loss of some procedures or actions which may affect the physical environment. Ideally, mockups should be built in a real clinical environment with the real equipment / elements to give the participating nurses a more realistic setting.

Participants' awareness of being observed or videoed may change their behaviors (Smith et al, 1993) and affect the space required. Next, due to the lack of walls or curtains as space boundaries in the mockup, some participants might have been so sensitive to the lines on the floor that they restricted their movements and couldn't concentrate on carrying out the tasks. On the other hand, some participants might have forgotten about the wall or curtain boundaries so they stepped out or moved the equipment/furniture further than they needed to. Both of the above situations could lead to bias of the results. During the simulations, we have therefore used lightweight screens mounted on the casters to represent the walls and curtains. The participants were reminded of the space boundaries but could easily push the screens when they needed more space to carry out the tasks.

As Stanton (1983) said "badly positioned equipment in theoretically adequate overall space would prevent the room from being used as intended", a limitation of simulations was obviously that the simulations were carried out within layouts, which were taken from the site visits and might not have been optimal.

4. CONCLUSIONS

Villeneuve (2000) suggested that ergonomics would complement architecture rather than competing with it, so ergonomic methodology has a lot to offer architects and building planners. To produce a research-based or user-centered design, a detail knowledge of work processes within a defined space/area is needed. A range of ergonomic methods including task analysis and user-needs analysis could be used to provide this information (Rutter, 1996).

This study validates the transfer of task analysis methodologies for other safety critical service industrials for use in the healthcare industry. A protocol for the future revision and testing of NHS Estates ergonomic drawings can therefore be developed.

5. REFERENCES

Hilliar, P. (1981) *The DHSS Ergonomics Data Bank and the Design of Spaces in Hospitals*. Applied Ergonomics, 12 (4), 209-216.

- Kozer, E., Seto, W., Verjee, Z., Parshuram, C., Khattak, S., Koren, G., and Jarvis, D. A. (2004) *Prospective Observational Study on the Incidence of Medication Errors During Simulated Resuscitation in a Paediatric Emergency Department*. BMJ, doi:10.1136/bmj.38244.607083.55 (published 28 September 2004).
- Lu, J., and Hignett, S. (2005) *Questioning the Use of NHS Estates Ergonomic Drawings*. In Bust P. and McCabe P.T. (Eds.) *Contemporary Ergonomics*. Taylor and Francis, London. pp266-270.
- Rutter, B. G. (1996) *Environmental Design Technologies: Designing the Ergonomically Correct Medical Environment*. Proceedings from the Eighth Symposium on Healthcare Design. Nov 16-19. San Diego, California. *Journal of Healthcare Design*. 8, 127-131.
- Shepherd, A. (2001) *Hierarchical Task Analysis*. Taylor and Francis, London. pp8-24.
- Smith, M., Macintosh, P., Sverrisdottir, A., and Robertson, C. (1993) *Improved Coordination Makes for Faster Work: Ergonomic Analysis of a Trauma Resuscitation Room*. *Professional Nurse*, 8, 711-715.
- Stanton, G. (1983) *The Development of Ergonomics Data for Health Building Design Guidance*. *Ergonomics*, 26 (8), 375-393.
- Villeneuve, J. (2000) *The Contribution of Ergonomics to the Design of Hospital Architecture*. In: Proceedings of the IEA 2000/HFES 2000 Congress – a CD-ROM.
- Villeneuve, J. (2004) *Participatory Ergonomic Design in Healthcare Facilities*, chapter 11, in Charney W. and Hudson A. (Eds.) *Back Injury among Healthcare Workers*. Lewis Publishers, Boca Raton, FL. pp161-178.