

Measurement of the noise production in drainage pipes

W.G. van der Schee (1)

(1) w.g.vd.schee@wolterendros.nl

Abstract

In the Netherlands new regulations for housing have come into force that require a reduction in noise levels in domestic buildings caused by installations. The maximum allowed noise level is 30 dB(A). This low level has consequences for how the installations are designed and installed. The new regulations have also initiated new methods in constructing buildings.

TVVL and Uneto-VNI have initiated a study with the aim to develop new guidelines and a calculation model. These new guidelines will be used to update the current guidelines which enables consultants and installers to select the correct materials and sound insulation measures to meet the required noise level in rooms.

The scope of the study covers:

- Measuring the noise production caused by different flow velocities in various drainage pipe materials.
- Measuring the noise reduction by using several sound insulation measures.

Keywords

Noise reduction, sound insulation, drainage pipes

1. Introduction

Noise caused by sanitary installations both in the same house or from the adjacent house plays an important role. With regard to tougher regulations on the quality of residential buildings in general, the reduction on the noise levels in residential buildings has come about. The requirements in relation to noise levels caused by (sanitary) installations are set out in public (Bouwbesluit) and private regulations (GIW): the maximum allowed noise level is now 30 dB(A). This is quite a stringent maximum level. In residential buildings noise is generated in piping systems, which also transmit the noise through contact with the structure. Solutions to this problem are usually not simple because of the many sources at which the noise may originate and because of the complex mechanism by which noise travels and is eventually radiated to the room.

Designers and technicians need practical information how to design and install pipe systems in buildings in order to avoid high noise levels in buildings. Guidelines are available, but it is unknown if the existing guidelines meets the new very strict permitted maximum value of 30 dB(A).

In the study a total of 550 measurements were carried out in the field of sanitary installations. The study covers the following: (1) literature research, (2a) measurements on the noise production of water pipes, (2b) measurements on the noise production of drainage pipes and (3) publication of the report.

This paper is a summary of stage 2b of the study report and covers the measurements on drainage pipes and describes:

1. The methodology used to measure the noise production in drainage pipes.
2. A summary of the results of the measurements

2. Measurements

To get information on the noise emitted by horizontal drainage pipes, measurements were conducted in an acoustical laboratory. The purpose of these measurements is to get insight in the expected noise level in a room caused by a toilet discharging in a horizontal drainage pipe.

The main items of the study are:

1. measuring the sound production of a bare drainage pipe.
2. measuring the influence of external acoustical insulation of a drainage pipe.
3. measuring the influence of an enclosure around the drainage pipe.
4. measuring the influence of different types false of ceiling.
5. measuring the influence of a combination of the items mentioned above

The measurements were made in collaboration with TVVL, Uneto-VNI and several manufactures who provided products and materials such as pipe material, acoustic insulation, suspended ceiling systems and lighting fittings.

3. Methodology used to measure the noise production

The variables as mentioned below have been examined:

- The constructive situation.
- Material of the drainage pipes.
- A variable flow in the drainage pipe.
- Different sound insulation materials and sound insulation measurements.
- Different types and qualities of false ceilings.

The measurements were carried out in the acoustical laboratory of Peutz bv in Mook in the Netherlands according:

- NEN-EN 14366:2004 Laboratory measurement of noise from waste water installations.

- NEN-EN-ISO 140-3:1995 Acoustics – measurement of sound insulation in buildings and of building elements – Part 3: Laboratory measurements of airborne sound insulation of building elements.

3.1 Calculations

To compare the measured noise levels with other situations the measured values are recalculated to a standard reference sound pressure level L_n in dB(A). By measuring the reverberation time of the measure room the equivalent absorber area is calculated with:

$$A = 0,163 \frac{V}{T} \quad (1)$$

Where:

A = equivalent absorption area (m^2 area of opening)

V = Volume of the test room (m^3)

T = Reverberation time of the test room (s)

The measured sound pressured levels L_p for the various constructions are corrected for the actual absorber area A and recalculated to a standard reference sound pressure level L_n with a reference absorber area of $10 m^2$ open window:

$$L_n = L_p + 10 \log \frac{A}{A_o} \quad (2)$$

Where:

L_n = sound pressure level (dB)

L_p = measured sound pressure level caused by the flow in the water pipe (dB)

A = according (1) determined absorption area (m^2 area of opening)

A_o = reference absorption area ($10 m^2$ area of opening)

3.2 Measurement set up

The drainage pipes were installed in a special acoustical laboratory. A pump with a variable speed was installed. From the pump water runs in a vertical pipe to a horizontal pipe connected to a vertical waste stack. The water makes a free fall trough the vertical waste stack along a T-junction and two 45° bends, then it flows into the investigated horizontal pipe. Outside the measurement room the water returns to the reservoir. See figure 1, 2 and 3 for the experimental set-up. The pipes were installed by a certified plumber. In the drainage pipe the falling water generates noise and vibrations. The sound radiated by the drainage pipe was measured in the measurement room with a moving microphone. The measurements were done with various flows: 0.5, 1.0, 2.0, 3.0 and 4.0 l/s.

Depending on the kind of measurement a drainage pipe was installed, a casing around a drainage pipe was constructed or a suspended ceiling system was constructed. The background noise in the reverberation chamber in which the pipes were installed was monitored to ensure it was always 10 dB below the noise radiated by unenclosed pipes for frequencies above 125 Hz.

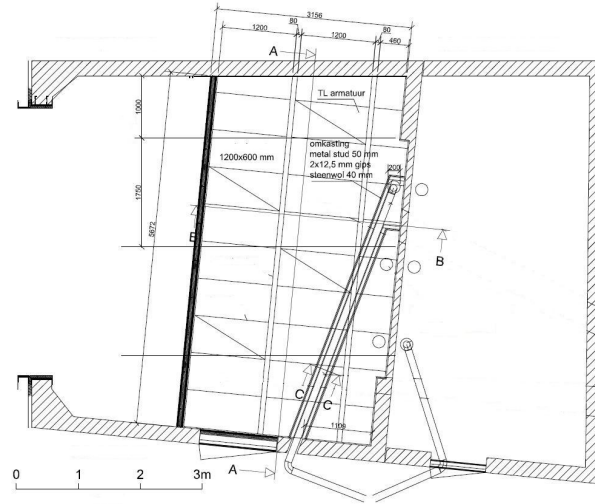

Figure 1 - Plan measurement room

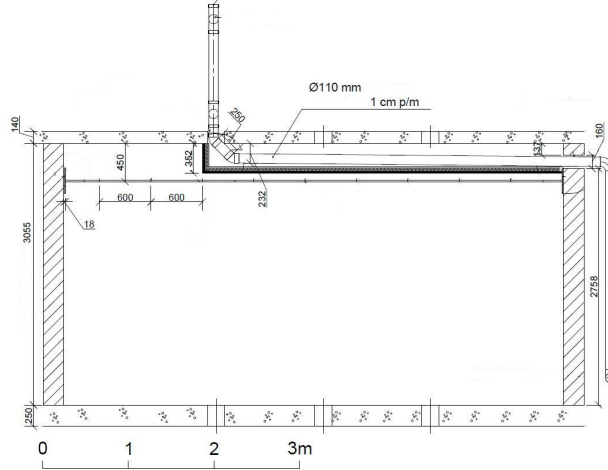

Figure 2 – Cross section A-A of the measurement setup with a horizontal drainage

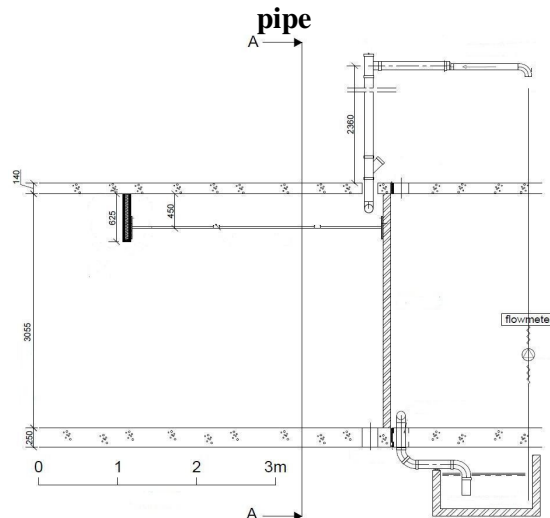

Figure 3 – Cross section B-B of the measurement setup with pump

4. Materials and constructions

The noise production of the drainage pipes as mentioned in table 1 were measured.

Table 1 – Measured types of drainage pipes







Drainage pipe	Picture
Type PVC U-Ultra 3 Mass 1.3 kg/m ¹ Inside diameter 103 mm Outside diameter 110 mm	
Type Wavin AS Mass 3.5 kg/m ¹ Inside diameter 98 mm Outside diameter 110 mm	
Type PAM Global (SML) Mass 8.5 kg/m ¹ Inside diameter 103 mm Outside diameter 110 mm	
Type Polyethylene Mass 1.23 kg/m ¹ Inside diameter 103 mm Outside diameter 110 mm	
Type Geberit Silent-db20 Mass 3.5 kg/m ¹ Inside diameter 93 mm Outside diameter 110 mm	
Type DykaStil Mass 1.88 kg/m ¹ Inside diameter 107 mm Outside diameter 110 mm	

Table 2 gives examples of the used clamps to fix the drainage pipe. Standard clamps and clamps with a rubber inlayer were used.

Table 2 – Examples of used clamps



Type of clamp		Picture
Manufacturer	Walraven	
Type	BIS 4000	
Standard		
Manufacturer	Walraven	
Type	BIS 5000	
With rubber inlayer		
Manufacturer	Saint Gobain	
Type	Tyrodur 128	
With rubber inlayer		

Table 3 shows the acoustical insulation.

Table 3 – Outside acoustical insulation

Acoustical insulation	Picture
Manufacturer	
Type	
Corn	
Outer layer	
	Insulation Solutions
	Sonorex Easy Tube 23
	10 mm glass wool
	Thickness 2 mm, mass 4 kg/m ²

Table 4 describes an enclosure of gypsum board with internal insulation.

Table 4 – Enclosure of gypsum board with insulation



Composition	Image
Stud wall, profiles 50 mm	
Double gypsum board, 12.5 mm, mass 8.6 kg/m ²	
Glass wool, 40 mm, mass 14.6 kg/m ³	

Table 5 – Ceiling tiles

Description ceiling tiles	Picture
Ceiling variant A1 Material Glass wool Manufacturer Saint-Gobain Ecophon Type Ecophon focus A Thickness 20 mm Mass $\approx 1.6 \text{ kg/m}^2$	
Ceiling variant C1 Material Rock wool Manufacturer Rockwool-Rockfon Type Sonar 44 Thickness 50 mm Mass $\approx 8.4 \text{ kg/m}^2$	
Ceiling variant C2 Material Glass wool, 12.3 mm plaster Manufacturer Saint-Gobain Ecophon Type Combison Uno A Thickness 34 mm Mass $\approx 10.7 \text{ kg/m}^2$	

5. Comparison with a toilet

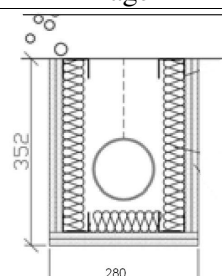
The noise measurements on the drainage pipes were executed with a continuous steady flow of 0.5, 1.0, 2.0, 3.0 and 4.0 l/s. In practice the noise generated by a toilet discharging into a drainage pipe is governing.

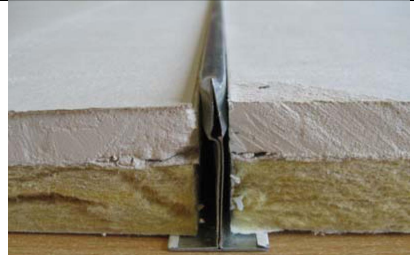
Most sounds that need to be measured fluctuate in level. To measure the sound properly we want to be able to measure these variations as accurately as possible. However, if the sound level fluctuates so rapidly, displays change so erratically that it is impossible to get a meaningful reading. For this reason, two detector response characteristics were standardized. These are known as “F” (Fast) and “S” (Slow). “F” has a time constant of 125 milliseconds and provides a fast reacting display response enabling us to follow and measure not too rapidly fluctuating sound levels. “S” with a time constant of 1 second gives a slower response which helps average-out the display fluctuations on a meter, which would otherwise be impossible to read using the “F” time constant. According to the standard the maximum sound pressure level of a source has to be measured with a response characteristic “S” (slow).

To determine the relation between the sound pressure level of a continuous steady flow in a drainage pipe and the various flow of a toilet discharging in a drainage pipe measurements were done with a real toilet situated above the measurement room and connected to the vertical stack and drainage pipe. See figure 4.

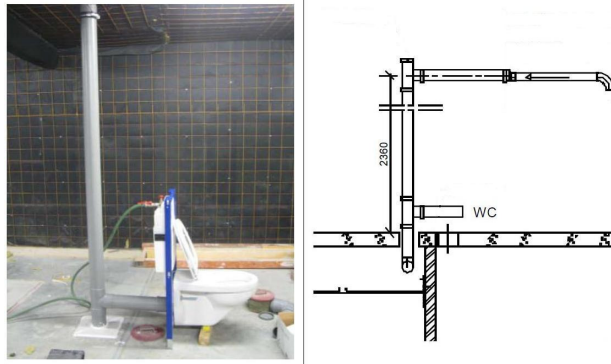

Figure 4 – Measurement set up with a toilet above the measurement room

The sound pressure level caused by a flushing toilet was measured and analysed in eleven compositions with different pipe material, clamps and false ceilings. For each flush the maximum sound pressure level with a response characteristic “F” (Fast) and “S” (slow) is determined. For each composition three flushes were measured and afterwards the average value was calculated. This approach leads to the conclusion that the sound pressure level measured in the setting “F” (Fast) with a continuous flow of 3.0 m/s in a drainage pipe, is comparable with the sound pressure level of a flushing toilet.

6. Three basic setups

Figure 5 shows three setups for basic pipes; (A) an offset vertical with two 45° bends, (B) a straight pipe and (C) a horizontal pipe. Table 6 shows the measured sound pressure levels of these three variants and pipe materials for a flow of 3.0 l/s.

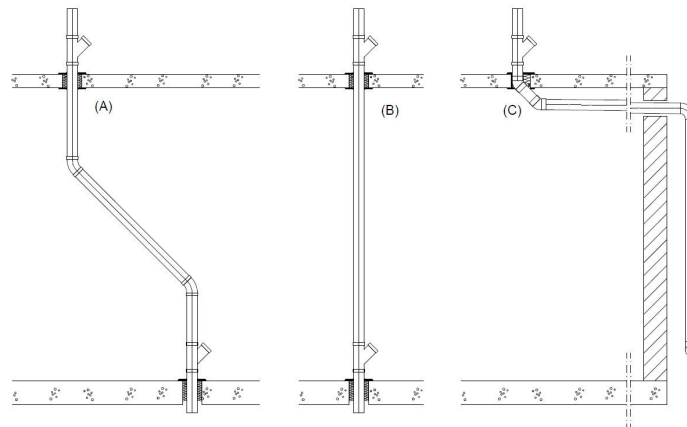

Figure 5 – (A) Offset vertical, (B) straight vertical and (C) a horizontal pipe installed in the measurement room

Table 6: Sound pressure level L_n in dB(A) for three variants and pipe materials, flow 3.0 l/s

Pipe material	L_n in dB(A)		
	Offset vertical (A)	Straight Vertical (B)	Horizontal pipe (C)
PE-SDR 26	n.m.	58.0	n.m.
PE-SDR 32	67.5	61.0	64.5
PP	66.5	55.5	61.0
PVC	64.5	57.5	61.0
AquaSilent	62.5	54.0	56.5
DykaSono	58.5	53.5	55.5
DykaStil	61.0	54.5	56.0
Geberit Silent 20 dB	62.0	53.0	57.0
Wavin AS	58.0	52.0	53.5
SML cast iron	n.m.	51.0	50.5
n.m. = not measured			

It turns out to be that the sound pressure level of a offset vertical with two 45° bends is higher than a vertical and horizontal pipe. The same conclusion applies for the horizontal pipe compared with the vertical pipe. The cast iron pipe has the lowest noise production. For the cast iron pipe the sound pressure levels are similar for the straight vertical pipe and the horizontal pipe.

7. Influence of acoustic insulation used on the drainage pipe

7.1 External acoustic insulation reduces the noise production

The noise production of a drainage pipe reduces if the drainage pipe is insulated with external acoustic insulation. The level of the reduction depends on the pipe material and acoustic insulation. The acoustic insulation material was fixed around three pipe materials: PVC, Wavin AS and SML cast iron. Figure 6 graphically illustrates the measurement results as reduction of the noise level in dB per frequency band and dB(A) in relation with a bare drainage pipe.

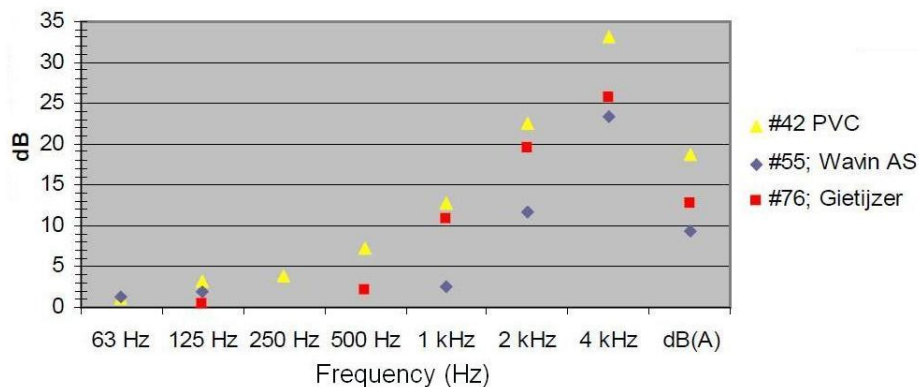

Figure 6 - Noise reduction in dB and dB(A) of acoustic insulation for PVC, Wavin AS and SML cast iron, flow 3.0 l/s

7.2 Partial insulation of the horizontal drainage pipe

It's also possible to insulate a part of the horizontal drainage pipe. Therefore pieces acoustic insulation material were removed in steps of 0.5 metre, and for every step the noise reduction is determined. At the first step the first 45° bend is insulated and at the second step the two 45° bends are insulated. Subsequently the length of the acoustic insulation increases with steps of 0.5 metre. At 4.5 metre the drainage pipe is insulated over the full length. Figure 7 shows the measurement set up and figure 8 graphically illustrates the noise reduction for PVC, Wavin AS and SML cast iron drainage pipes.

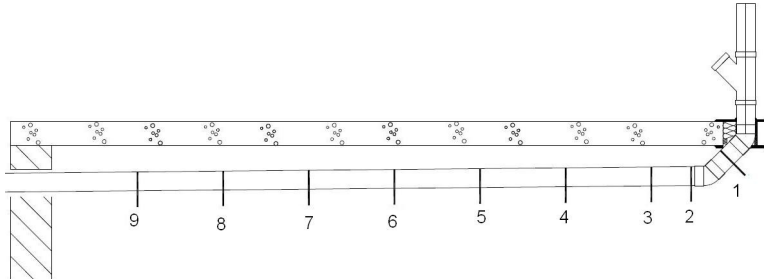

Figure 7 – Set up to measure the influence of acoustic insulation in steps of 0.5 metre

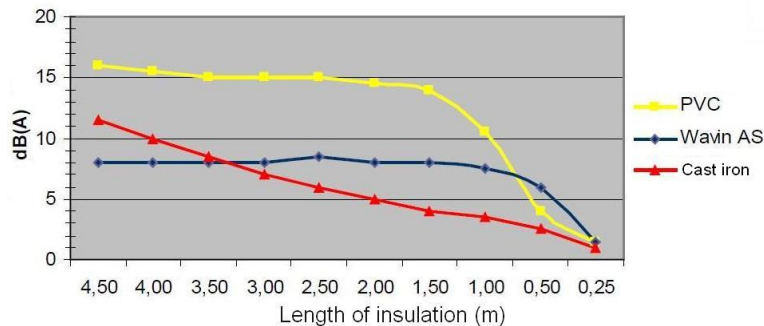

Figure 8 – Noise reduction of acoustic insulation in steps of 0.5 metre for PVC, Wavin AS and SML cast iron, flow 3.0 l/s

7.3 Conclusions acoustic insulation

The noise reduction of a drainage pipe depends on the material of that particular pipe. The influence of the external acoustic insulation increases when the sound pressure level of the bare pipe is high and when the mass of the pipe material is low.

The material of a drainage pipe has influence on the required length of the acoustical insulation and on the effect of the acoustical insulation. So it isn't necessary to insulate the full length of the PVC drainage pipe. There is no significant reduction of the noise level if the pipe is insulated over a longer distance than 1.5 metre.

However, for the cast iron pipe it is. This has to do with the attenuation and stiffness of the cast iron. The generation of noise takes place in the bends and the more the distance from the bends increases, the more the vibrations and sound level decreases.

8. Influence of an enclosure around the pipe

8.1 Measurements

An other way to reduce the sound radiation of a drainage pipe is to add an enclosure around the pipe. The enclosure is described in table 4. Figure 9 shows the construction and dimensions in detail. For absorption and isolation 40 mm glass wool is fixed on the inside. The noise reduction is measured for three pipe materials: PVC, Wavin AS and SML cast iron. Figure 10 graphically illustrates the noise reduction in dB per frequency band and dB(A).

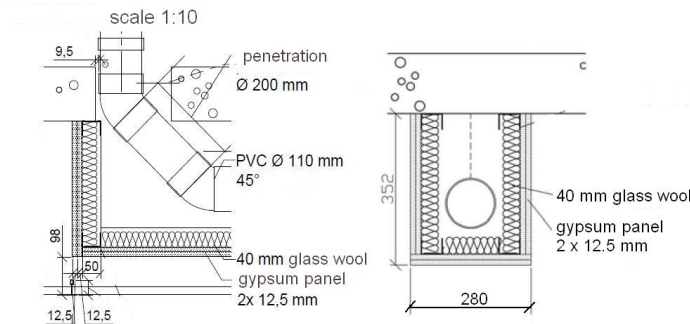

Figure 9 – Construction of the enclosure with acoustic insulation inside

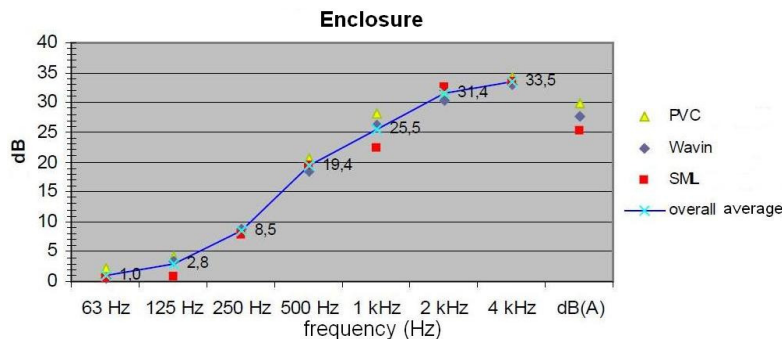

Figure 10 – Noise reduction of an enclosure with acoustic insulation inside for PVC, Wavin AS and SML cast iron

8.2 Conclusions of an enclosure around the pipe

An enclosure around the drainage pipe reduces the noise very effectively. In this case the pipe material has almost no influence on the effect of the noise reduction. This creates the possibility to determine an average value for noise reduction of an enclosure and to use this value in a calculation model.

9. Influence of a suspended ceiling system

9.1 Measurement setup

To determine the influence of a false ceiling on the noise radiation the noise reduction was measured and calculated. The noise reduction was measured for three pipe materials: PVC, Wavin AS and SML cast iron, with a height of 460 mm above the false ceiling.

9.2 Suspended ceiling with Ecophon Focus A tiles

The Ecophon Focus A ceiling tile is a light glass wool panel with a high absorption properties but has limited isolation properties. See table 5 for the description of the material. This ceiling tile is measured in combination with four lighting fittings without noise silencers. Figure 11 graphically illustrates the noise reduction in dB per frequency band and dB(A) of the Ecophon Focus A ceiling tile.

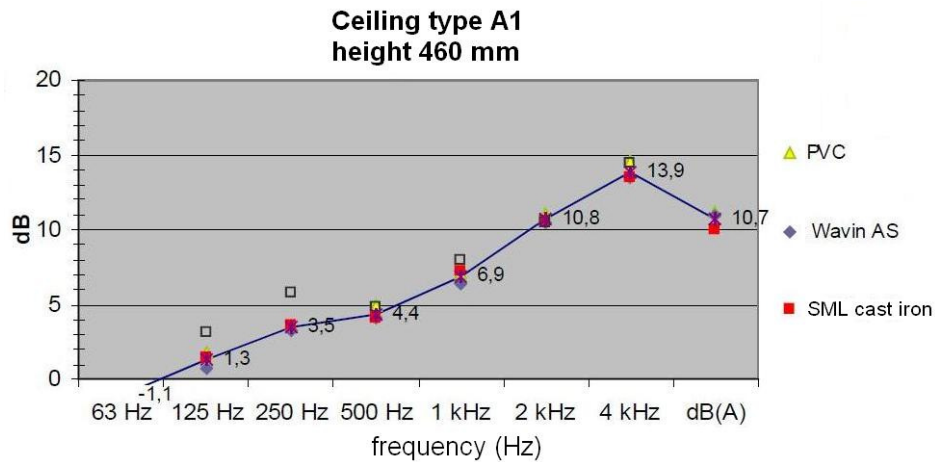

Figure 11 – Noise reduction of a false ceiling with Ecophon Focus A ceiling tiles, height 460 mm

9.3 Suspended ceiling with Rockfon Sonar 44 tiles

For the description of the Rockfon Sonar 44 ceiling tile see table 5. The ceiling panel is a sandwich composition with an absorption layer on the under site, a heavy corn and a absorption layer on the back. The lighting fittings are equipped with sound silencers on the top. Figure 12 graphically illustrates the noise reduction in dB per frequency band and dB(A) of this ceiling construction.

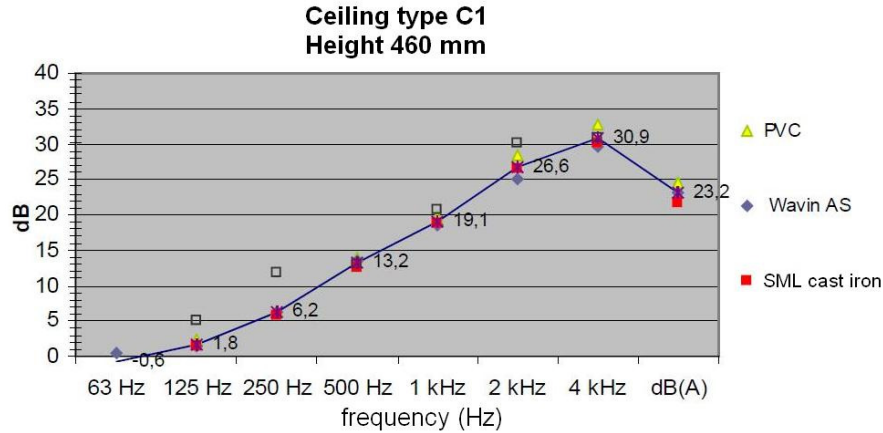

Figure 12 – Noise reduction of a false ceiling with Rockfon Sonar 44 ceiling tiles, height 460 mm, and lighting fittings equipped with sound silencers

9.4 Suspended ceiling with a Ecophon Combison Uno A tiles

For the description of the Ecophon Combison Uno A ceiling in detail see table 5. The composition of this ceiling panel consist of a sandwich construction with an absorption layer on the under site and a 12.3 mm gypsum layer on the back.

The lighting fittings are equipped with sound silencers on the top. Figure 13 graphically illustrates the noise reduction of this ceiling construction in dB per frequency band and dB(A).

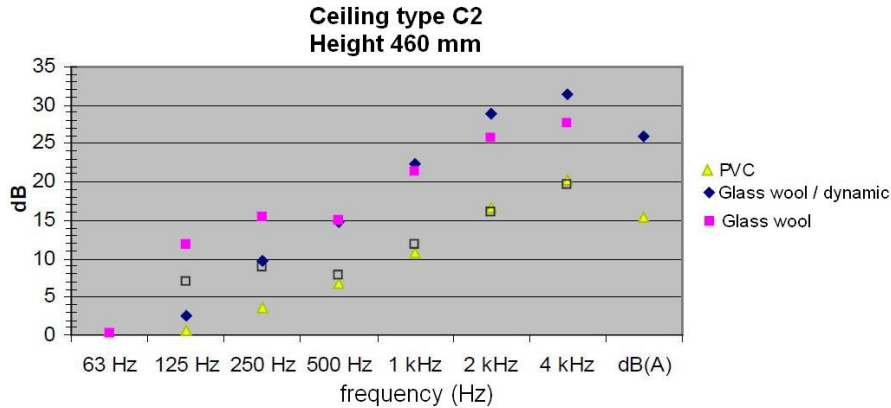

Figure 13 – Noise reduction of a false ceiling with Ecophon Combison Uno A tiles, height 460 mm, and lighting fittings equipped with sound silencers

9.5 Conclusions suspended ceiling systems

The noise reduction of the suspended ceiling systems varies between about 10 dB(A) for light types of ceiling and about 15 dB(A) for type C1 and about 25 dB(A) for the best attenuation.

10. Conclusions

Based on the measurements in the laboratory a continuous flow of 3.0 l/s is applicable as acoustic equivalent for the maximum sound pressure level caused by a flushing toilet. The measured sound pressure levels for a horizontal pipe varies between 61 dB(A) for a standard PVC drainage pipe until 53 dB(A) for a silent type of drainage pipe. The sound pressure level caused by a horizontal offset is higher than for a vertical drainage pipe. The sound pressure level caused by a offset vertical is higher than for a horizontal drainage pipe. A cast iron drainage pipe has the lowest sound pressure level. With the investigated acoustic pipe insulation (outer layer 2 mm and 10 mm glass wool) a noise reduction between 8 and 18 dB(A) is measured. The noise reduction depends on the pipe material. The higher the sound radiation of the pipe the higher the effect of the acoustic insulation.

As enclosure of a double gypsum board with absorption material inside, fixed free from the drainage pipe leads to a reduction of the noise level between 25 and 30 dB(A). The reduction is independent of the pipe material.

For the suspended ceiling systems three different qualities of ceiling panels were measured:

- The most simple version is a light glass wool panel with high absorption properties but with low insulation properties. With this type of ceiling the noise level caused by a horizontal pipe reduces in average with 10 dB(A).
- The second investigated ceiling panel is a pressed mineral fibre with a mass of about 4 kg/m². This ceiling system reduces the noise level in average with 23 dB(A).
- The suspended ceiling system with the best performance is a ceiling with a multi layer construction of glass wool and gypsum, and lighting fittings equipped with sound silencers. This type of ceiling reduces the noise level in average with 25 dB(A).

The outcome of the measurements offers the possibility to develop a calculation model to predict the sound pressure level caused by a flushing toilet in a room. The calculation model will provide to choose the right measures to meet a defined noise limit in a room.

11. References

Measurements on the noise production of horizontal drainage pipes; August 2011; Peutz; in the Netherlands.

Presentation of author

Walter van der Schee is a member of the Dutch Technical Association for Building Installations (TVVL). He is a member of the board of the department Sanitary Technologies (ST). The objective of the association is to promote research and technology in the field of building services. This is done by networking; giving courses; lectures; organising symposia; research and co-financing university-chairs. For further information see www.tvvl.nl



Walter van der Schee is employed at Wolter & Dros where he is responsible for the engineering of installations in buildings. Further information see www.wolterendros.nl